

ELECON **SCOOP CONTROLLED-VARIABLE SPEED FLUID COUPLING**

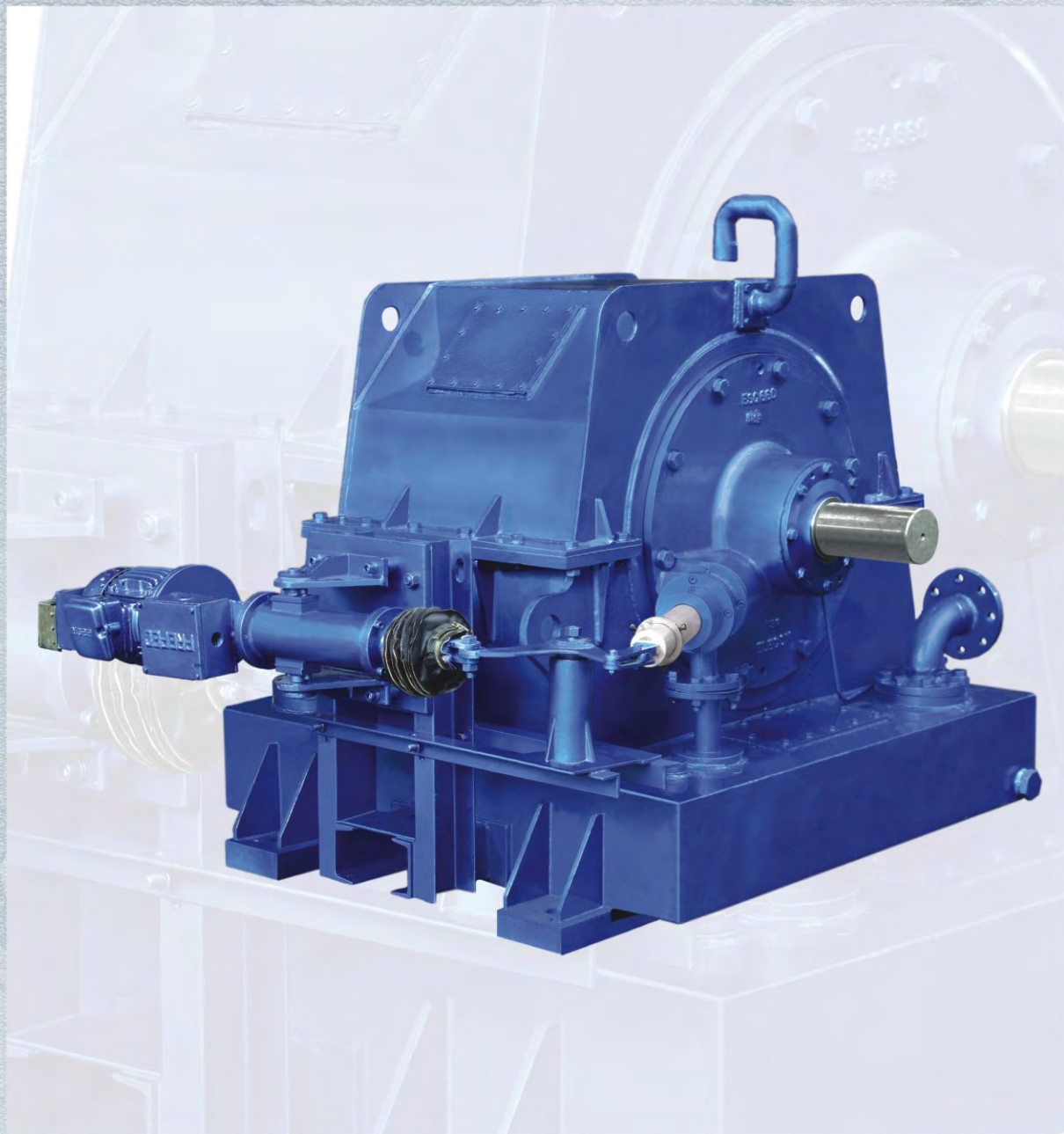

ELECON 

Always a step ahead in technology

PREAMBLE

In today's world where the natural resources are depleting with considerable speed, sensible use and conservation of these is the need of the hour. 'conservation of natural resources' has become the Global concern. Modern technology also has not lagged behind in this war; constant endeavors are being made to improve the technology so as to help save precious energy and in the process money also. One outcome of our efforts is development of Scoop Controlled - Variable Speed Fluid Coupling.

In industries the deciding factor for choosing the prime mover (motor) for a machine is the power required to start the machine from standstill condition, called the starting torque, which is considerably higher – 150% to 200% of the power required to keep the machine running. In simple terms - if 3 kW power is needed to keep a machine running, for starting the same machine from standstill condition we will require a power of 5-6 kW power which ultimately, decides the rating of the motor that will run the machine, which obviously results in the wastage of precious energy.

What one could wish for is the starting of motor on no-load condition, a control over the starting torque as the machine accelerates, continues declutching if required, stepless speed variation wherever needed, synchronous running of a number of motors in a multidrive system with load limiting for the safety of motor as well as of the machine... etc. ELECON's scoop controlled - variable speed fluid coupling is an answer to fulfill this wish list.

CONSTRUCTION & FUNCTION

Variable speed fluid coupling comprises of a stationary housing (2 & 3), which also serves as the sump and this fully supports and covers the rotating mass. The working circuit (12) is the chamber between the Impeller (4) and the Runner (5). The Impeller is connected to a rotating scoop chamber that consists of a primary casing (6) and secondary casing (7). The amount of oil in the working circuit determines the output speed of the coupling and is dependent upon the radial position of the scoop tube (8) in the scoop chamber. The scoop tube slides radially in to the chamber through the stationary housing and the position of the scoop tube inside the chamber can be governed externally by the actuator and can also be operated manually. The position of the tip of the scoop tube directly trims the volume of the oil in the working circuit carried from completely filled to completely drain while in operation thus providing infinitely variable speed control over the speed of the driven machine over a large range. The labyrinth seal with oil seal (10) ensures no oil leakage from shaft end.

A pump via filter and the heat exchanger (oil cooler) maintains the working oil circulation.

The variable speed fluid coupling is designed in such a way that it is suitable for various site conditions and also has low vibrations and noise level.

Various controls, pipe lines, sensor, etc. can be very easily mounted. Adoption of various types of controls, sensor than the standard one as per requirement is also very easy.

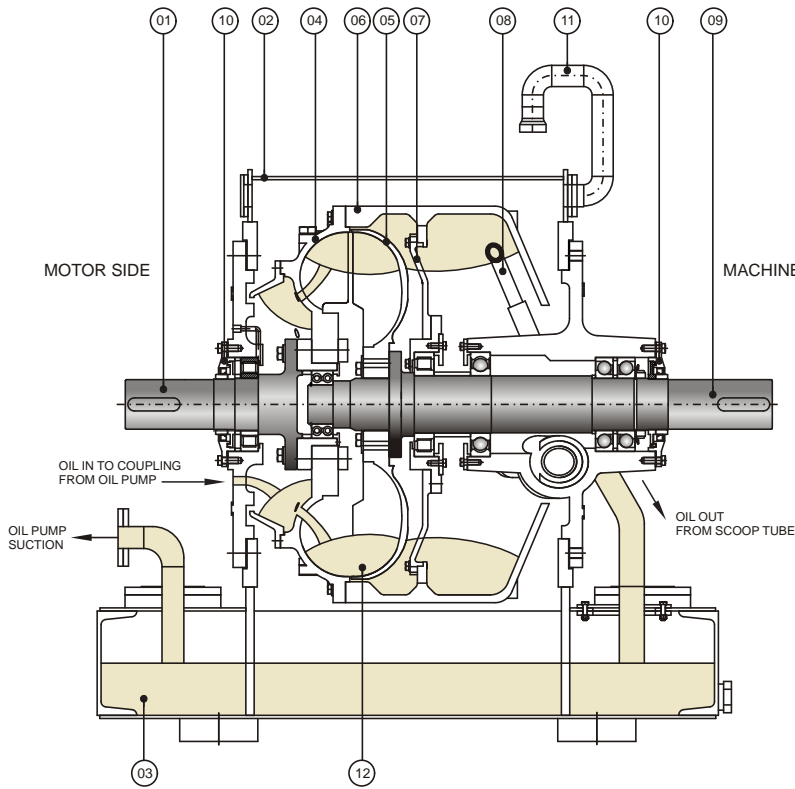

PART NO.	DESCRIPTION
01	IMPELLER SHAFT
02	UPPER HOUSING
03	LOWER HOUSING
04	IMPELLER
05	RUNNER
06	PRIMARY CASING
07	SECONDARY CASING
08	SCOOP TUBE
09	RUNNER SHAFT
10	LABYRINTH SEAL WITH OIL SEAL
11	BREATHER PLUG
12	WORKING CIRCUIT

CONSTRUCTION

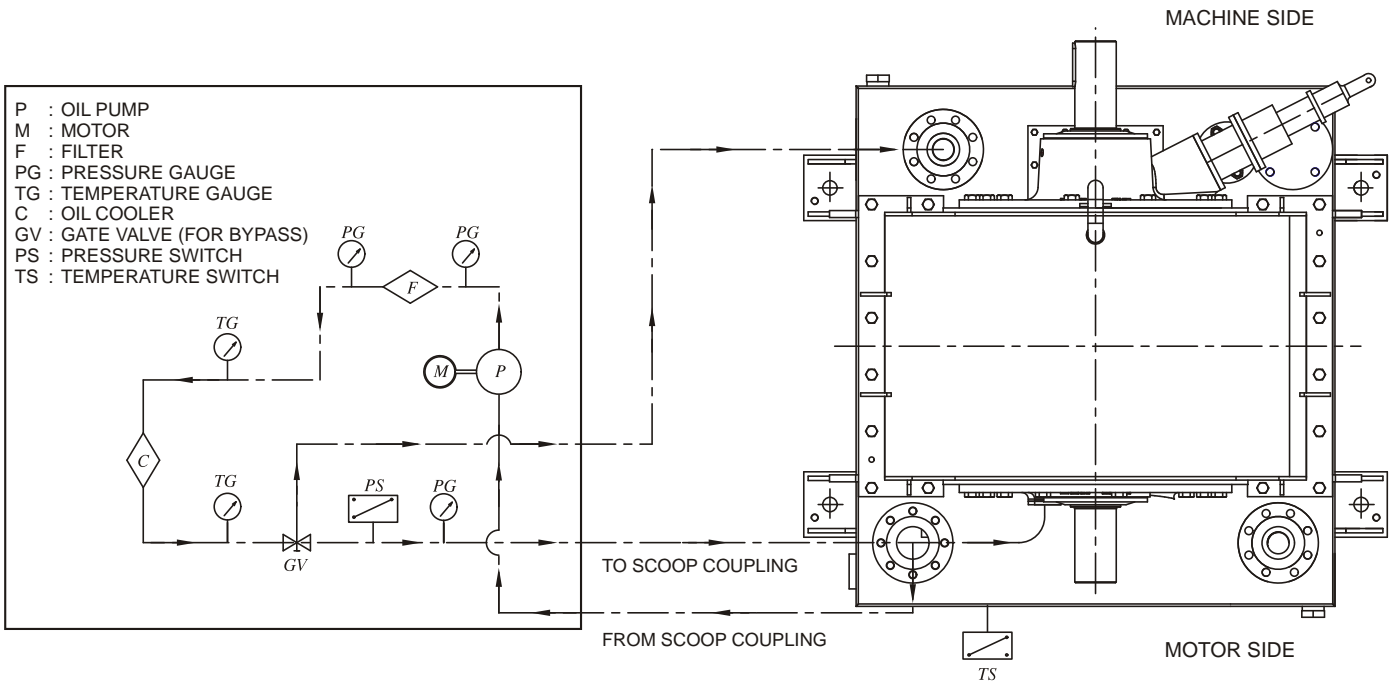

OIL CIRCUIT DIAGRAM

ADVANTAGES

- Saving in first cost, by allowing the use of simple squirrel cage motor in place of costly slip ring motor. This squirrel cage motor is sized for the running condition and not for starting duty as the variable speed fluid coupling allows no-load start of motor.
- Smooth & controlled acceleration of heavy masses from stationary to running condition which improves service life of the motor.
- Saving in running cost by energy saving, when the variable speed fluid coupling is used to reduce the speed of fan/pump to control the discharge instead of using dampers, vanes, valves etc.
- Low maintenance cost due to wear-free power transmission through hydrokinetic energy.
- There is mechanical separation between driving & driven equipments which protects the motor & driven machine by dampening of torsional vibrations and shock load.
- High control accuracy and fast reaction times.
- Easy to operate, robust design & long service life.
- Easy governing of scoop tube position by actuator or manually for speed control.
- The rotating mass is covered by self-supported stationary housing which does not load the motor and machine bearings. Also, no hazards of accidents.
- The labyrinth seal with oil seal ensures no oil leakage from shaft end.
- Various controls, pipe lines, sensors, etc. can be easily mounted.
- Suitable for various site conditions.

APPLICATIONS - Various Industries

- **Material Handling :**
 - Belt Conveyors
 - Crushers
 - Ring Granulators
- **Power Plant :**
 - Fans
 - Pumps
- **Chemical Industry :**
 - Fans
 - Pumps
 - Mixers
- **Oil & Gas Industry :**
 - Compressors
 - Pumps
- **Metallurgical Industry :**
 - Blowers
 - Pump

SELECTION TABLE

		Power Transmitted in kW					
Motor Speed (rpm)		750	900	1000	1200	1500	1800
Coupling Size	ESC-480	22	38	52	90	175	302
	ESC-584	47	81	111	192	375	455
	ESC-660	81	140	193	333	650	1123
	ESC-760	147	255	350	605	1050	-
	ESC-870	350	605	830	1494	2147	-
	ESC-1030	850	1469	1925	2320	-	-

REQUEST : For power & speed not covered by this table, please consult ELECON.

SELECTION CHART

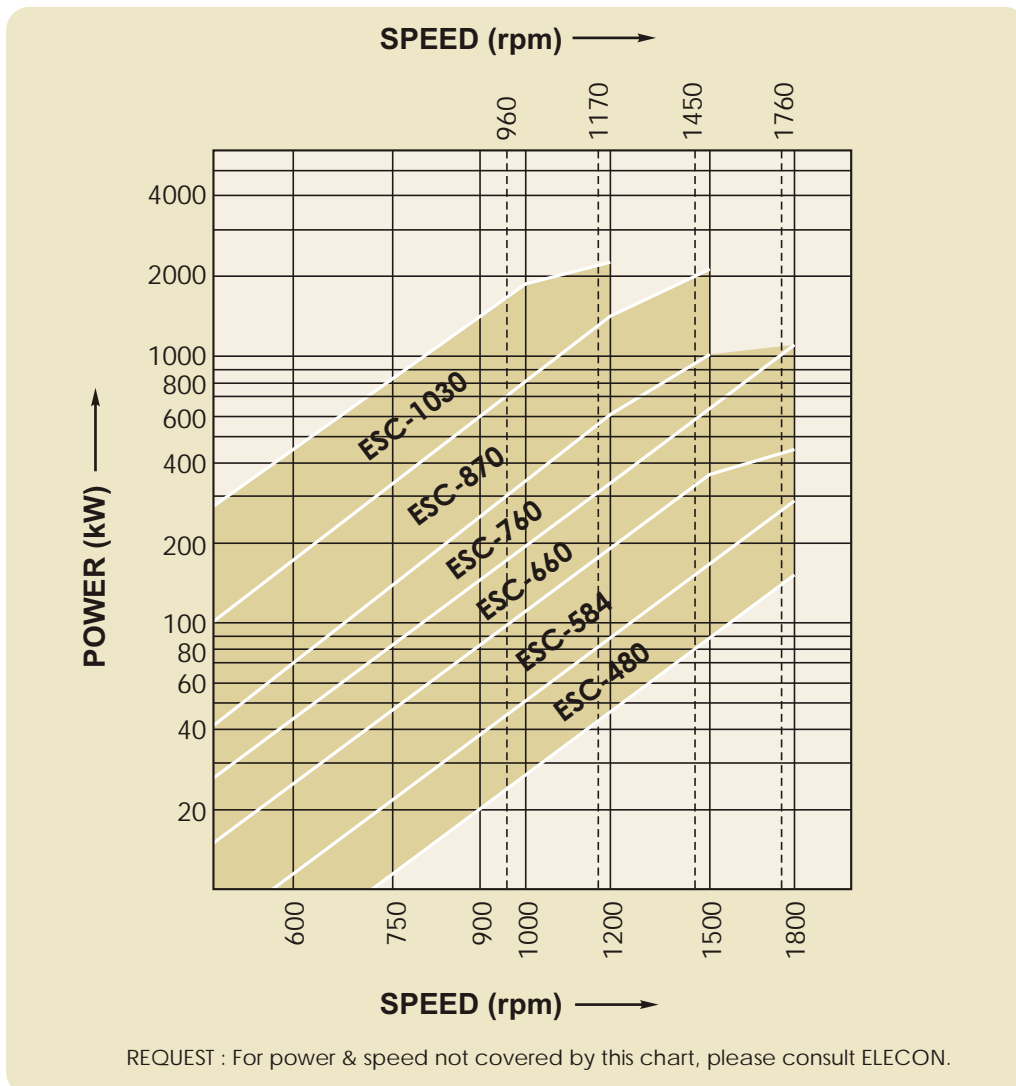

Owing to continuous development and improvement, all dimensions and characteristics are subject to change without notice.

SIZE : ESC-480

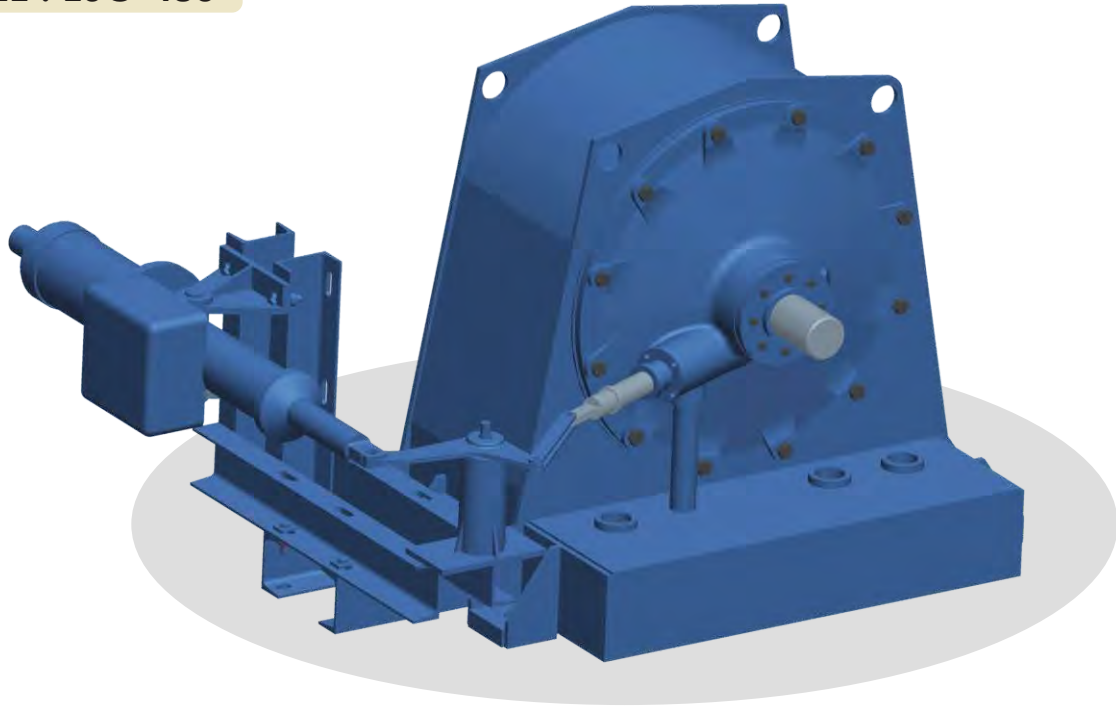

MOTOR SIDE

MACHINE SIDE

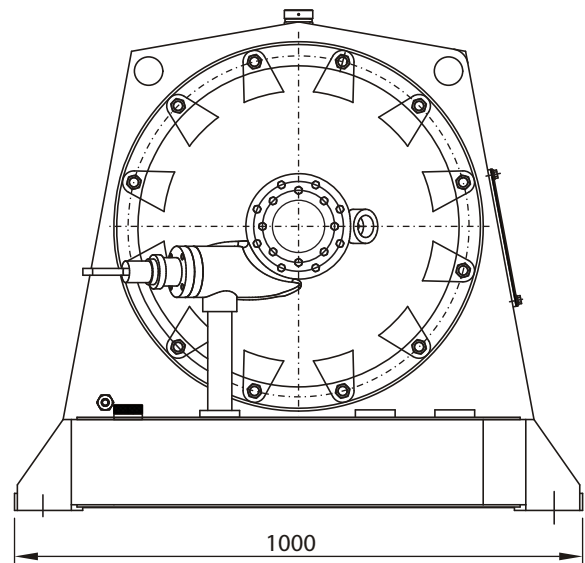
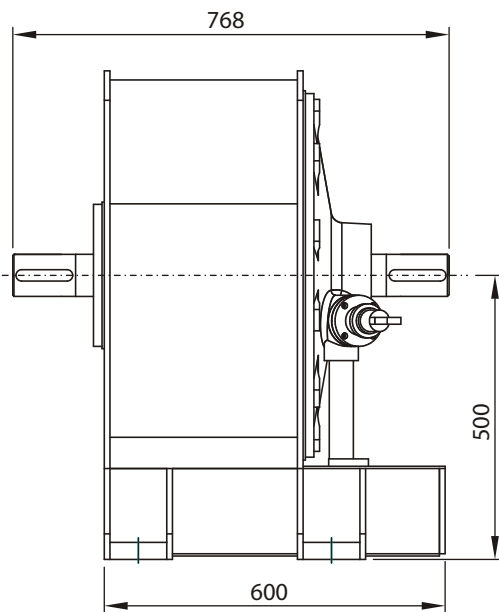

All dimensions are in mm.

Owing to continuous development and improvement, all dimensions and characteristics are subject to change without notice.

SIZE : ESC-584

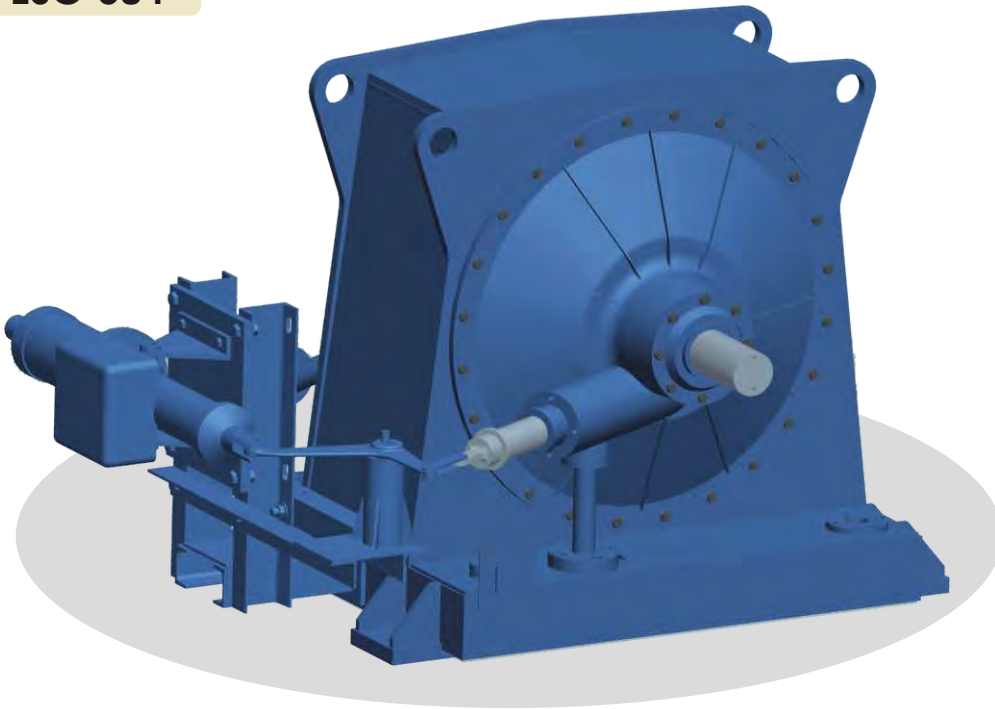

MOTOR SIDE

MACHINE SIDE

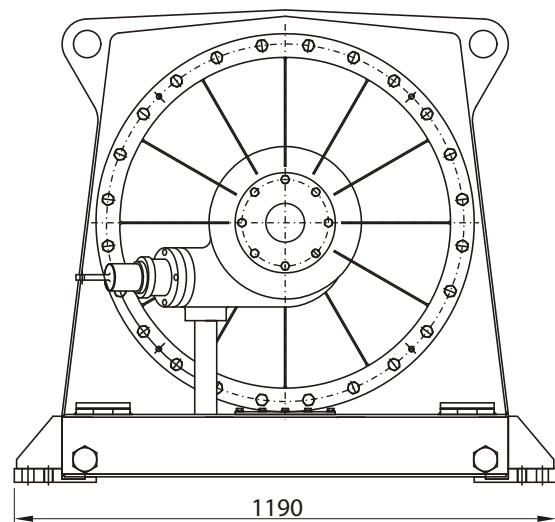
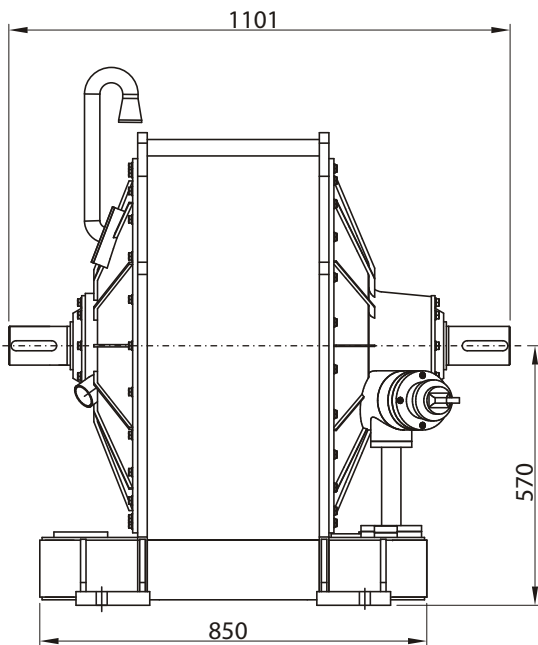

All dimensions are in mm.

Owing to continuous development and improvement, all dimensions and characteristics are subject to change without notice.

SIZE : ESC-660, ESC-760, ESC-870 & ESC-1030

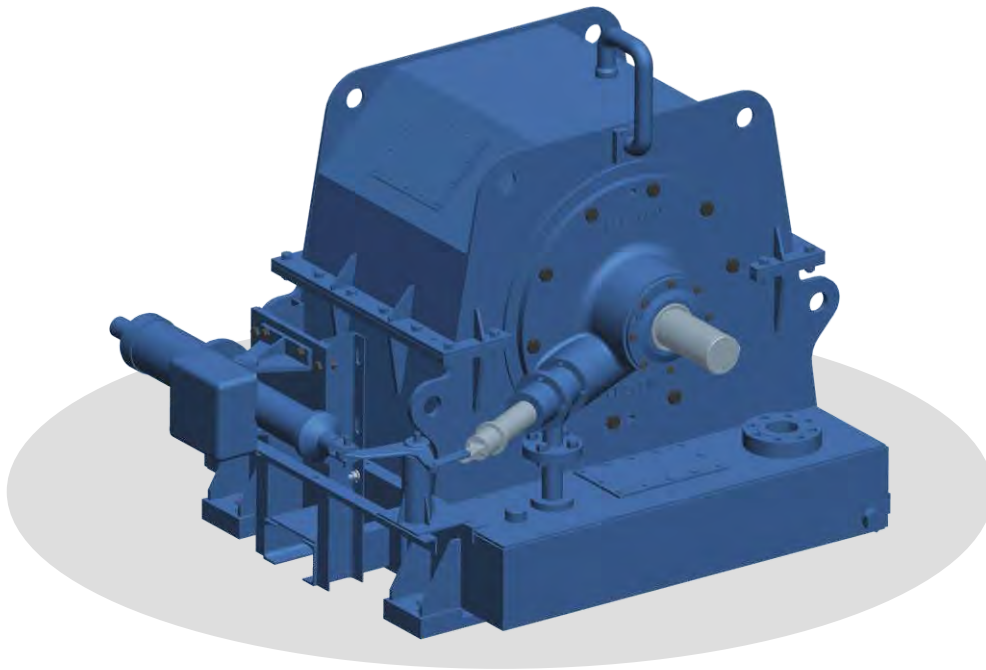

MOTOR SIDE

MACHINE SIDE

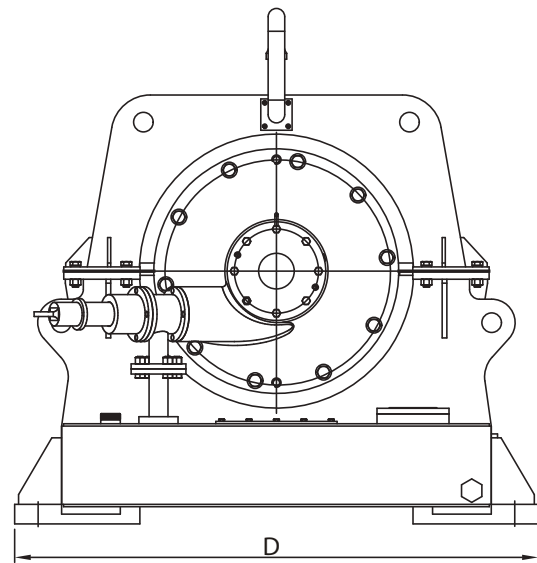
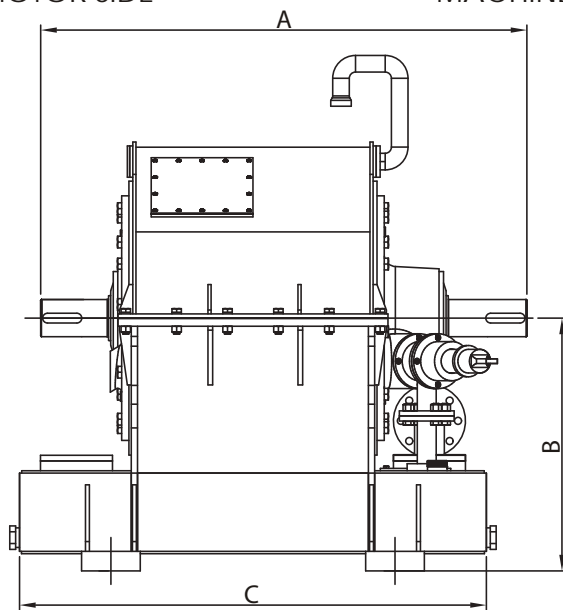

All dimensions are in mm.

SIZE	A	B	C	D
ESC-660	1243	646	1193	1338
ESC-760	1281	733	1300	1820
ESC-870	1395	790	1450	1640
ESC-1030	1520	875	1600	1840

Owing to continuous development and improvement, all dimensions and characteristics are subject to change without notice.

OPERATING AND CONTROL RANGES

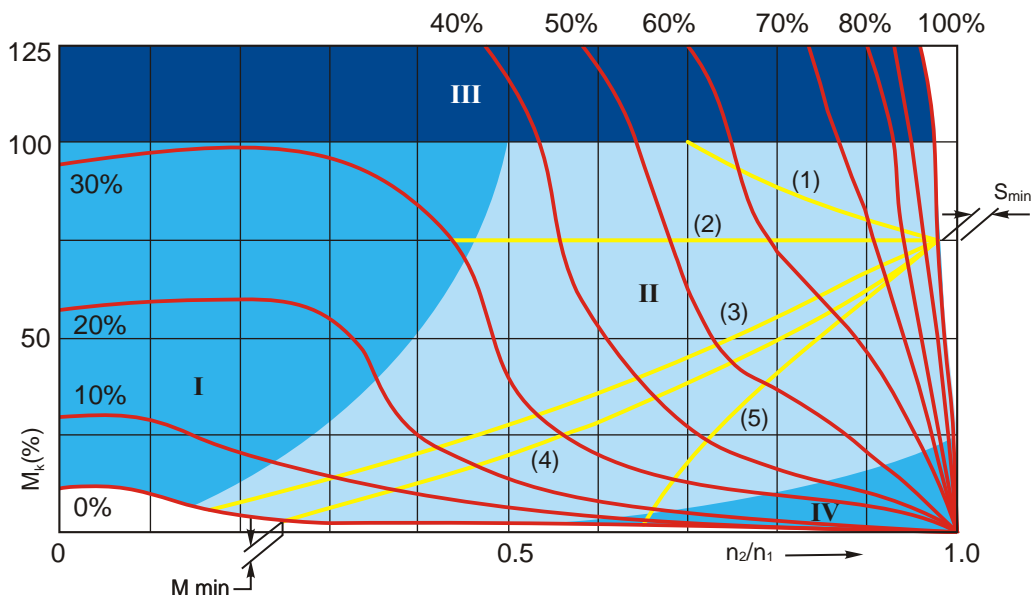

CHARACTERISTIC CURVE

The above diagram shows the operating range of the variable speed fluid coupling. The coupling torque (M_k) which can be transmitted at varying scoop tube ratios as a function of the speed ratio $n_1 : n_2$ is shown. The characteristics are divided into different ranges marked I to IV.

Control range II is the main operating range of the variable speed fluid coupling. In this range the various load characteristics have been entered. It includes the torque and speed range where high control precision can be achieved.

The desired output speed n_2 is the stable intersection of coupling torque M_k (Coupling characteristic) and load torque (load characteristic).

The two coupling characteristics that limit the control range are: the characteristic of the 100% scoop tube position reflect the maximum output speed attainable under load conditions and the so called rated slip, S_n is maintained; the characteristic for 0% scoop tube position shows the required minimum load torque M_{min} for the desired speed range.

The required speed adjustment is achieved by changing the slip between the impeller and runner.

Typical Load Characteristics

- (1) Rising torque (e.g. processing pump for changes in viscosities or specific weight)
- (2) Constant torque (e.g. conveyor belts, volumetric pumps with constant pressure)
- (3) Decreasing torque (e.g. boiler feed pumps operating at various pressures)
- (4) Parabolic torque (e.g. resistance parabolas, pumps without back pressure, blowers)
- (5) Decreasing torque (e.g. boiler feed pumps operating at fixed pressure)

Operating Ranges

- I, IV Starting Range
- II Control Range
- III Overload Range

The shape of the coupling characteristic curve is given for information only, since there may be minor deviations if coupling sizes, circulating oil flow, oil viscosity etc. vary.

Parameters

Scoop tube position is in % of the full scoop tube stroke.

- M_k : Coupling Torque
- M_{min} : Min. torque required for min. speed adjustment
- S_{min} : Min. slip required for torque transmission
- S_n : Rated slip at design point
- S : $(1 - n_2/n_1) \times 100$ [%]
- n_1 : Input speed
- n_2 : Output speed

Owing to continuous development and improvement, all dimensions and characteristics are subject to change without notice.



Fluid, Flexible & Gear Couplings

MARKETING & SERVICING COMPANY



EMTICI ENGINEERING LIMITED

REGISTERED OFFICE :

Anand - Sojitra Road, Vallabh Vidyanagar - 388 120, Gujarat, INDIA Phones : +91 269 223 0168, +91 269 223 1125 Fax : +91 269 223 6508
Website : www.emtici.co.in

NATIONAL BRANCHES :

AHMEDABAD :

Phone : (079) 26406683, 26406684, 26406685
Fax : (079) 26401363
E-mail: sales@ahdemtici.elecon.com

BILASPUR :

Phones : (07752) 247723, 247625
Fax : (07752) 247720
E-mail : salesbil@bilemtici.elecon.com

INDORE :

Phone : (0731) 2558077
Telefax : (0731) 2558077

MADURAI :

Phone : (04549) 293488
Fax : (04549) 293468

NEW DELHI :

Phones : (011) 23414340, 23414341, 23414069
Fax : (011) 23709046
E-mail : salesdel@delemtici.elecon.com

ASANSOL :

Phones : (0341) 2305901, 2311726
Fax : (0341) 2302038
E-mail : salesasn@asnemtici.elecon.com

CHENNAI :

Phones : (044) 24349237, 24349497, 24322455
Fax : (044) 24349643
E-mail : salesmad@mademtici.elecon.com

JAMSHEDPUR :

Phones : (0657) 2361837, 2362376
Fax : (0657) 2464241
E-mail : salesjns@jimpemtici.elecon.com

MUMBAI :

Phones : (022) 22821315, 22820725, 22821365
Fax : (022) 22870791
E-mail : salesbom@bomemtici.elecon.com

PUNE :

Phones : (020) 40191400
Fax : (020) 40191420
E-mail : salespune@puneemtici.elecon.com

VADODARA :

Phone : (0265) 2312972, 23136701
Fax : (0265) 2312982
E-mail : salesbrd@brdemtici.elecon.com

INTERNATIONAL BRANCHES :

FAR EAST :

ELECON SINGAPORE PTE. LTD.
Phone : +65 622 782 58
Fax : +65 622 789 42
E-Mail : vipul@singapore.elecon.com
tejas@singapore.elecon.com

BANGALORE :

Phones : (080) 22260219, 22281834
Fax : (080) 22281834
E-mail : salesbgl@bglemtici.elecon.com

DHANBAD :

Phones : (0326) 2306283, 2302320
Fax : (0326) 2302320
E-mail : salesdhn@dhnemtici.elecon.com

KOLKATA :

Phones : (033) 24761861, 24760876
Fax : (033) 24761831
E-mail : salescal@calemtici.elecon.com

NAGPUR :

Phones : (0712) 6642600, 6642601, 6642602
Fax : (0712) 6642622
E-mail : salesnag@nagemtici.elecon.com

SECUNDERABAD :

Phones : (040) 27844748, 27845250
Fax : (040) 27848317
E-mail : salessec@secemtici.elecon.com

SOUTH AFRICA :

ELECON AFRICA PTY. LTD. :
Cell : +27 82900 6829
+ 27 832940291
E-Mail : gdramsay@mweb.co.za

MIDDLE EAST :

ELECON MIDDLE EAST FZCO
Phone : +97 146 091 424, +97 146 091 425
Fax : +97 146 091 426
E-Mail : rajen@dubai.elecon.com
milap@dubai.elecon.com
nirav@dubai.elecon.com



Always a step ahead in technology

Manufactured by :

ELECON ENGINEERING CO. LTD.

Post Box # 6, Vallabh Vidyanagar - 388 120, Gujarat, INDIA

MHE DIVN. : Tel. : +91 269 223 7016, +91 269 223 6521, +91 269 223 6590 Fax : +91 269 223 6457 E-mail : infomhe@elecon.com
GEAR DIVN. : Tel. : +91 269 223 6469, +91 269 223 6513, +91 269 223 6516 Fax : +91 269 223 6427 E-mail : infogear@elecon.com

Website : www.elecon.com